





# TECNA®



Advanced Resistance Welding Systems and Balancers

-  KIT DI SALDATURA A MEDIA FREQUENZA E TRASFORMATORE
-  MEDIUM FREQUENCY WELDING KIT AND TRANSFORMER
-  KIT DE SOUDAGE ET TRANSFORMATEUR A MOYENNE FREQUENCE
-  MITTELFREQUENZ-SCHWEISSKIT UND TRANSFORMATOR
-  KIT DE SOLDADURA DE MEDIA FRECUENCIA Y TRANSFORMADOR



The most advanced resistance welding machines

[www.tecna.net](http://www.tecna.net)

UNITA' DI CONTROLLO A MEDIA FREQUENZA  
MEDIUM FREQUENCY CONTROL UNIT

UNITÉ DE CONTRÔLE À MOYEN FRÉQUENCE  
MITTELFREQUENZ-STEUERUNG  
UNIDAD DE CONTROL DE MEDIA FRECUENCIA



Inverter Type [Art./Item]	Primary Current [A]
1591A	150
1591B	150
1592NA	300
1593NA	600
1594NA	900
1596NW	1500

TRASFORMATORI  
TRANSFORMERS

TRANSFORMATEUR  
TRANSFORMATOR  
TRANSFORMADOR

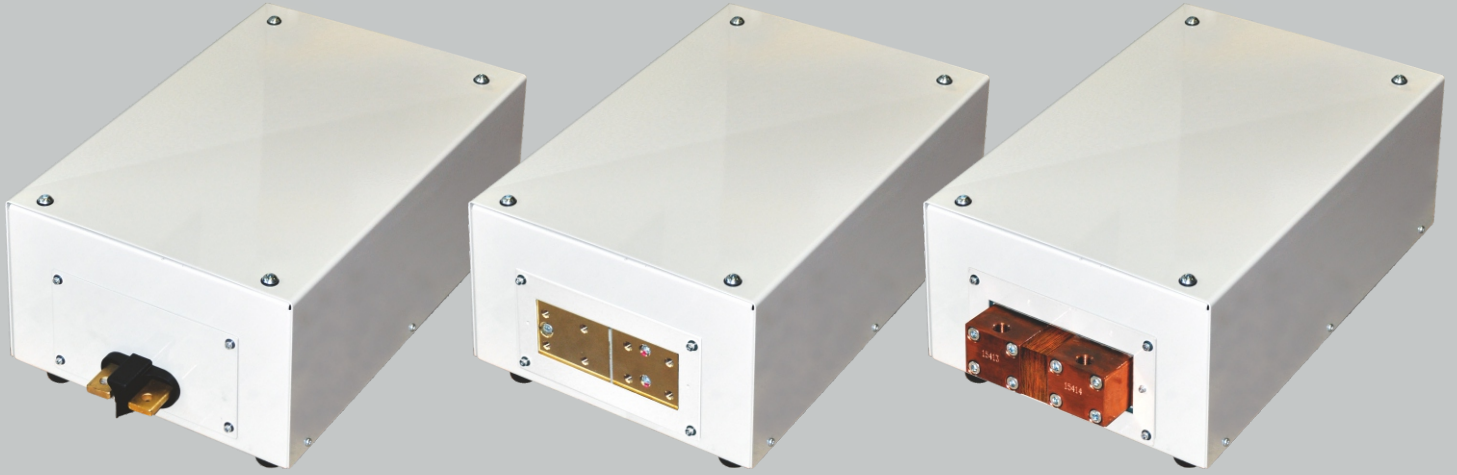

1587

1584 | 1585

1588 | 1589

TRANSFORMERS					
Transformer Type [Art./Item]	Power at 20% [kVA]	Power at 50% [kVA]	Secondary voltage [V]	Maximum weld current $I_{200}$ [kA]	Permanent out put current $I_{2p}$ [kA]
1587	40	25	14,5	9	4,3
1584	88	56	8	25	4,4
1585	142	90	9,4	32	5,4
1588	190	120	17,7	19	6,6
1589	205	160	12,3	40	8,8

TRASFORMATORI  
TRANSFORMERS

TRANSFORMATEUR  
TRANSFORMATOR  
TRANSFORMADOR

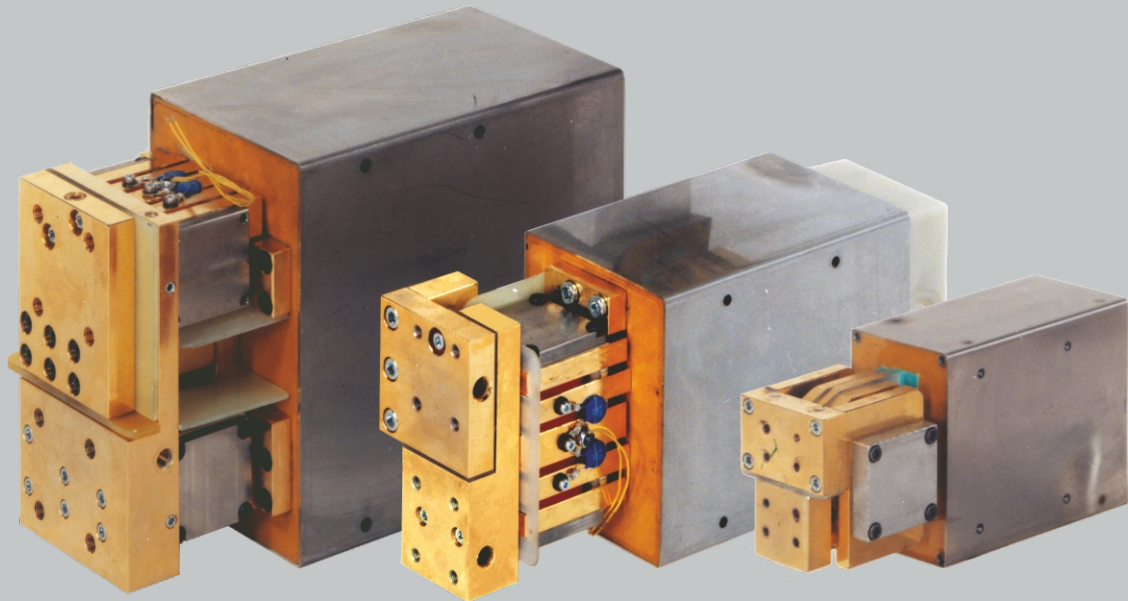





## TRANSFORMERS

Transformer Type [Art./Item]	Power at 20% [kVA]	Power at 50% [kVA]	Secondary voltage [V]	Maximum weld current $I_{2cc}$ [kA]	Permanent out put current $I_{20}$ [kA]
40443	40	25	14,2	9	4,3
40365	50	32	4,6	19	4,4
43737	80	51	6,1	19	5,4
40138	88	56	8,4	25	4,5
40139	142	90	9,9	32	6,1
37610	250	160	12,3	40	8,8
40314	316	200	10,4	60	15,3
40315	332	210	12	60	15,3
40266	380	240	10,9	75	15,9
40291	500	315	12,7	75	16,7

ARTICOLO   ITEM   ARTICLES   ARTIKEL   ARTICOLO			TE751 1591B	TE700 159XNA	1591A 1596NW
	<b>72288</b>	Kit sensore di posizione Position sensor kit Kit senseur de position Kit Positions-Sensor Kit sensor de posición	-	○	○
	<b>50214</b>	Scheda di interfaccia seriale RS 232 9 poli femmina 9-pin female RS 232 serial interface board Sortie sérielle RS 232 9 pôles femelle Serieller Schmittstelle RS 232 9-polig Tarjeta de interfaz serial RS 232 9 polos hembra	○	○	○
	<b>72278</b>	Scheda di interfaccia USB USB interface board Carte interface USB	-	○	○
	<b>72248</b>	Schnittstelle USB Tarjeta de interfaz USB	○	-	-
	<b>50200</b>	Scheda di espansione per campagna elettrodi Expansion board for electrodes dressing Carte d'expansion pour l'affûtage des électrodes Expansions-Printplatte für Elektrodenfräsung Tarjeta de expansión para afiladores electrodos	-	○	○
	<b>50367</b>	Scheda di interfaccia ETHERNET ETHERNET interface board Carte interface ETHERNET Schnittstelle ETHERNET Tarjeta de interfaz ETHERNET	-	○	○
	<b>50220</b>	Scheda per il pilotaggio di valvola proporzionale Board for controlling the proportional valve Carte pour le pilotage de la vanne proportionnelle Printplatte für Verwaltung Proportionalventil Tarjeta de control válvula proporcional	-	○	○

○ OPZIONALE. OPTIONAL. OPTIONNEL. OPTION OPCIONAL.

- NON DISPONIBILE. NOT AVAILABLE. PAS DISPONIBLE. NICHT VERFÜGBAR. NO DISPONIBLE.

ARTICOLO   ITEM   ARTICLES   ARTIKEL   ARTICOLO				TE751	TE700	
				1591B	159XNA	1591A 1596NW
	50300	Profibus	Modulo BUS di CAMPO FIELD Bus module Module des BUS de CHAMP Modul FIELD Bus Módulo de Bus de CAMPO	-	○	-
	50301	Devicenet				
	50302	CanOpen				
	50303	ETHERCAT				
	50304	Profinet				
	50305	EtherNet/IP				
	50307	Modbus RTU				
	72219	Profibus	Modulo BUS di CAMPO FIELD Bus module Module des BUS de CHAMP Modul FIELD Bus Módulo de Bus de CAMPO	-	-	○
	72220	Devicenet				
	72221	CanOpen				
	72222	ETHERCAT				
	72772	Profinet				
	72773	EtherNet/IP				
	73388	Modbus RTU				
	23287	TECNA Net		-	○	○
	50365	TE71	Terminale di programmazione Programming terminal Terminal de programmation Programmierungsterminal Terminal de programación	-	○	○
	73225	Kit Pirometro Pyrometer Kit Kit Pyromètre Pyrometer-Kit Kit de Pirómetro		-	○	○

○ OPZIONALE. OPTIONAL. OPTIONNEL. OPTION OPCIONAL.

- NON DISPONIBILE. NOT AVAILABLE. PAS DISPONIBLE. NICHT VERFÜGBAR. NO DISPONIBLE.

Art. / Item 1591A | 1591B

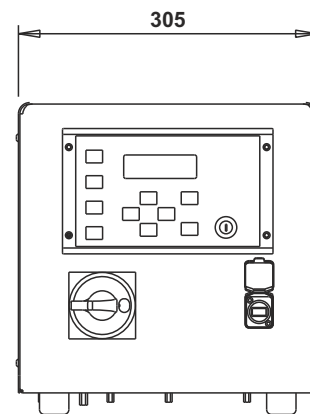
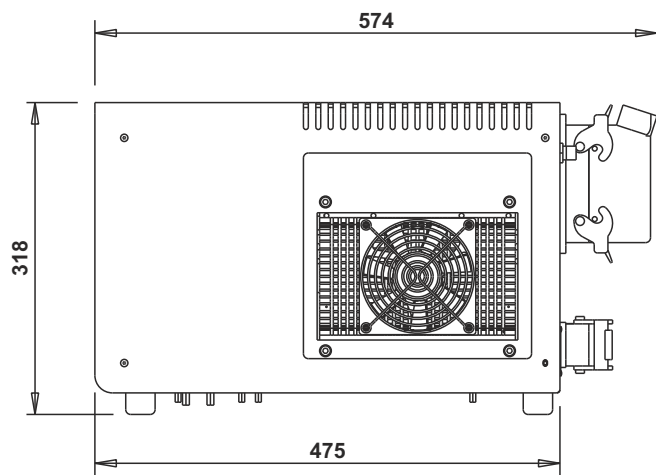

Art. / Item 1592NA | 1593NA | 1594NA | 1596NW

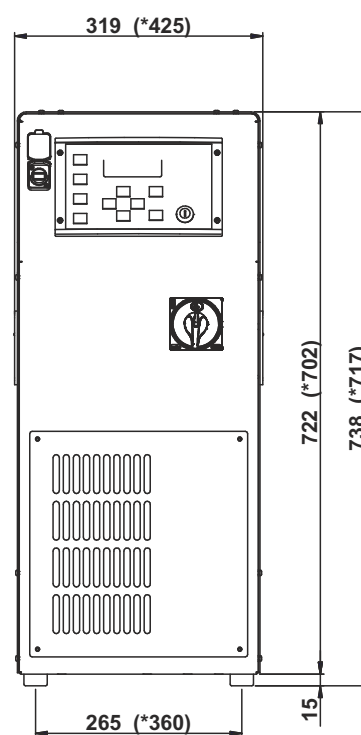
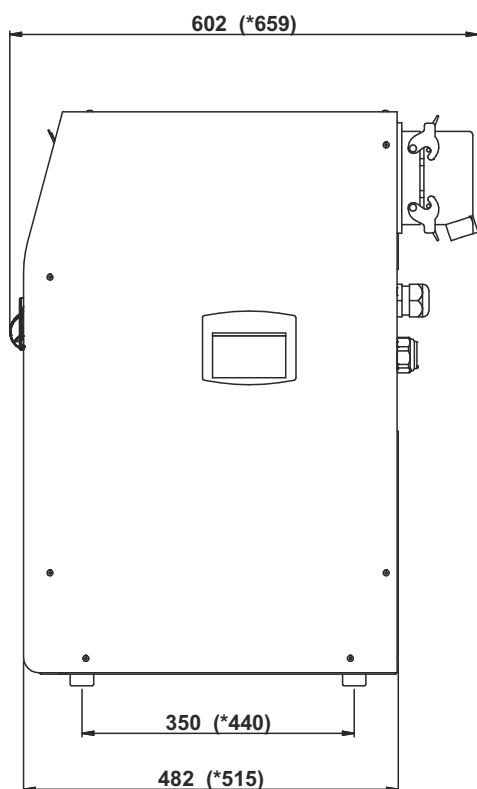

\*solo per art. 1596NW | \*only for item 1596NW | \*seulement pour l'art. 1596NW | \*nur für die Kunst. 1596NW | \*solamente para el art. 1596NW

Art. / Item 1584 | 1585 | 1587 | 1588 | 1589

